



OPERATION & PARTS LIST

PC401

EZY DECK PRO
GUN & HOPPER



DECKING & FLOORS

- Sprays a variety of textures
- Special tilting hopper for decking and floors
- Large hopper with T-handle for extra control
- Full grip trigger for less fatigue
- Designed for spraying a variety of overlay and decking material



PC400
EZY Deck
Pro Gun & Hopper
with Compressor

PC201

PROFORM®
TEXTURE GUN & HOPPER

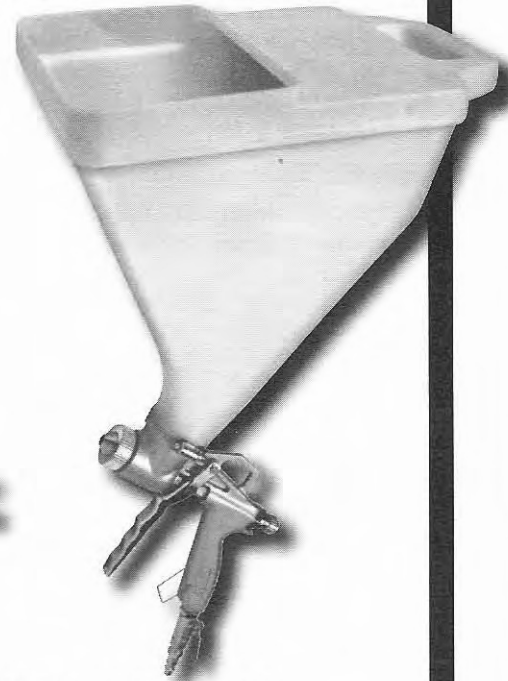

WALLS & CEILINGS

- Sprays a variety of textures
- Unique hopper angle for greater volume of material
- Large hopper with easy to grip molded handle
- Full grip trigger for less fatigue
- Designed for spraying a variety of textures on walls and ceilings



PC200
ProForm®
Texture Gun & Hopper
with Compressor

KRAFT

Operating & Maintenance Instructions

The Kraft PC200 & PC400 Texture Machines come with the following:

Texture Gun (PC406) Fits Both Hoppers (PC410 & PC559W):
(Comes with factory installed 2.5mm Air Nozzle)
(Comes with factory installed 8.0mm Orifice Nozzle)

Hopper with clamp:

White Hopper For Walls & Ceilings (PC201)
Gray Hopper For Decking & Floors (PC401)

Gun (Includes 3 Air Nozzles: 2.0 mm, 2.5mm, & 3.0mm)
3 Orifice Nozzles: 4.0mm, 6.0mm & 8.0mm

50' of 1/2" Air Hose With Compressor Attachment Fittings,
(See compressor assembly parts #20-23, See page 4
packed separately.

Compressor Assembly With Cart (PC400 & PC200).

Assembly Instructions

Gun To Hopper:

Place hopper clamp on hopper. Insert gun into bottom of hopper. Adjust and tighten hopper clamp to proper position. Secure gun to hopper. (See figure #1)

Hopper clamp

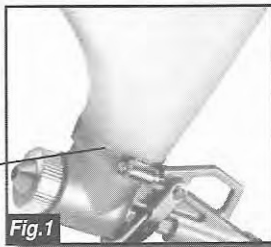

Fig.1

Hose to Compressor

(1) Remove plastic plug located at the front of compressor. (See figure #2)

Plastic Plug

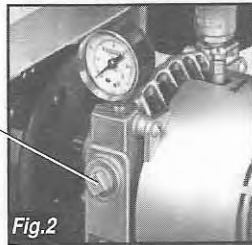

Fig.2

(See Figure #3)

- (2) Screw 1/2" all thread nipple into compressor.
- (3) Screw "T" fitting into all thread nipple.
- (4) Screw brass adaptor into opposite end of "T".
- (5) Screw relief valve into top side of "T".
- (6) Connect air hose to brass fitting.

Relief Valve
#PC530

Brass Adaptor
#PC518

Air Hose
#PC504

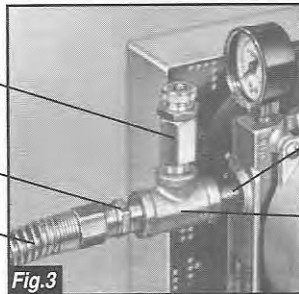

Fig.3

1/2"
All Thread
Nipple
#PC517

Pipe Tee
#PC516

Material Consistency

Follow the material manufacturer's instructions for correct consistency. A mix which is too stiff will not flow through the gun properly, resulting in irregular spray pattern.

Control of spray can be adjusted in four different ways: Air nozzle (PC406-07,08,09), Compressor (PC505), Fluid Control Knob Assembly (PC406-14) & Orifice Nozzles (PC406-02,03,04).

Note: For best results, always mix texture material with a drill type mixer.

Air Requirement:

The Kraft Compressor unit is rated at 6.2 CFM free air at 25 PSI.

(Note: If you are using your own compressor, it must have an equivalent or larger capacity than the Kraft compressor.)

The Kraft compressor is designed for continuous operation. There is no holding tank which builds reserve air. When the compressor is running, a continuous supply of air will flow through the gun.

Compressors

Using A Tank Type Compressor

Attach the shut off valve (PC406-28) to the bottom of the gun. Attach the quick coupler (PC555) to the shut off valve. Attach the 50' Hose (PC504) to the quick coupler. The shut-off valve allows you to stop the airflow from the compressor. If you turn the shut off valve to the closed position, air flow will stop and force the air into the reserve tank. The quick coupler will allow you to disconnect the air hose from the gun completely.

Using A Kraft Rotary Vane Compressor

Air flow

The amount of air which reaches the gun is controlled by the relief valve located at the front of the compressor. When tightened all the way down, the compressor will deliver maximum air to the gun. As the relief valve is backed off, air will bleed off through the top of the valve. This will decrease the amount of air which will reach the gun. The more air supplied to the gun the finer the pattern. As pressure decreases, the pattern will become course. (See Figure #4)

Relief Valve
#PC530

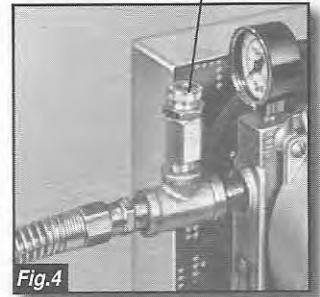

Fig.4

Caution:

Do not use shut off valve (PC406-28) with a rotary vane compressor. Attempting to use this valve without a reserve tank may cause equipment damage and/or oil blowing from pressure relief valve on compressor.

Gun Settings & Adjustments

Air Nozzle/Orifice Nozzle Settings

There are 3 sizes of Air Nozzles: 2.0mm, 2.5mm, & 3.0mm. The gun is shipped from the factory with the 2.5 mm Air Nozzle already installed. The diameter of the air nozzle determines the amount of air that disperses the material.

There are 3 sizes of Orifice Nozzles: 4.0mm, 6.0mm, & 8.0mm. The gun is shipped from the factory with the 8.0mm Orifice Nozzle. The larger diameter orifice nozzle will give you a wider pattern and a thicker texture. The smaller diameter orifice nozzle will give you a narrow pattern with a thin texture.

Trigger Adjustment/Fluid Control Knob

The position of the trigger determines the volume of material, but does not affect the air flow. As you adjust the Fluid Control Knob and pull back on the trigger, more material will flow from the gun. When the Fluid Control Knob is fully turned counter-clockwise, the trigger has maximum travel allowing for maximum flow of material. As the knob is tightened, trigger travel and material flow is reduced.

Fluid Control Knob
#PC406-14

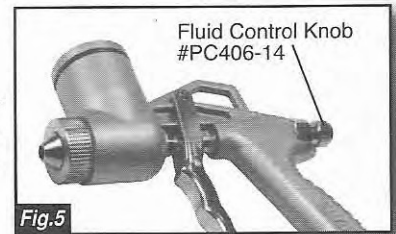
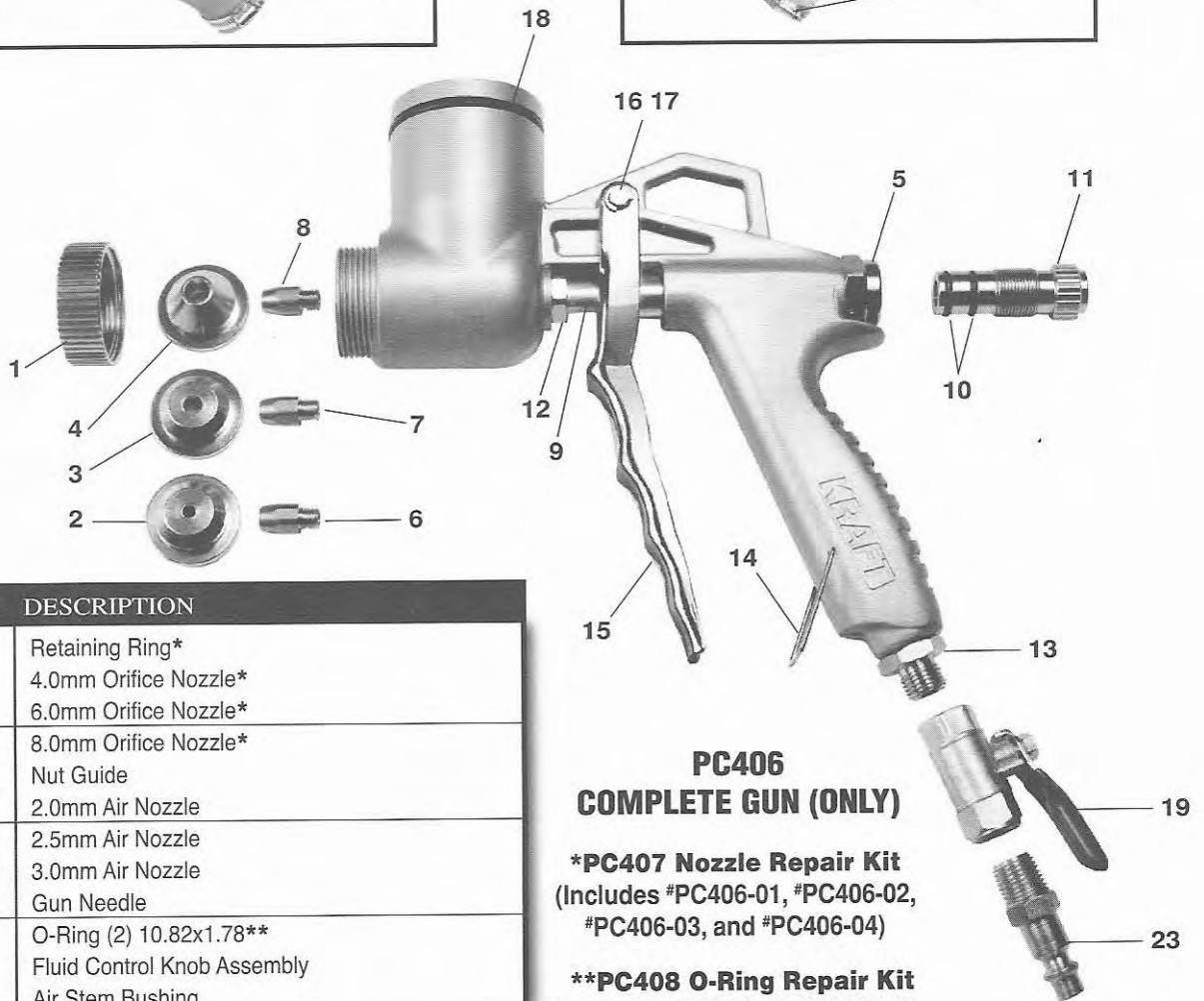
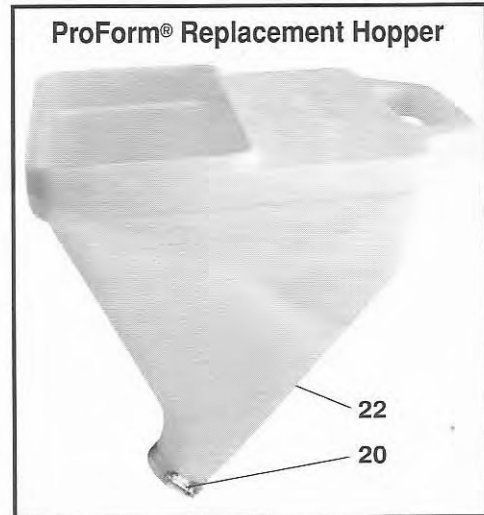
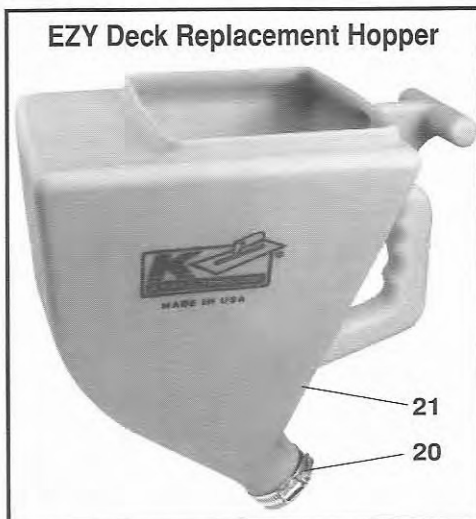

Fig.5

Test Patterns

It is recommended that you set your pattern on scrap material before spraying your finished product. Test your pattern by adjusting the Fluid Control Knob (PC406-14), and the relief valve on the compressor for material consistency. By experimenting with various air tips, orifice nozzles and the fluid control knob, you should be able to obtain your desired texture.



PC406 COMPLETE GUN (ONLY)

***PC407 Nozzle Repair Kit**
(Includes #PC406-01, #PC406-02,
#PC406-03, and #PC406-04)

****PC408 O-Ring Repair Kit**
(Includes #PC406-11, #PC406-13,
#PC406-19, and #PC406-27)

NO.	PART NO.	DESCRIPTION
1	PC406-01	Retaining Ring*
2	PC406-02	4.0mm Orifice Nozzle*
3	PC406-03	6.0mm Orifice Nozzle*
4	PC406-04	8.0mm Orifice Nozzle*
5	PC406-06	Nut Guide
6	PC406-07	2.0mm Air Nozzle
7	PC406-08	2.5mm Air Nozzle
8	PC406-09	3.0mm Air Nozzle
9	PC406-10	Gun Needle
10	PC406-11	O-Ring (2) 10.82x1.78**
11	PC406-14	Fluid Control Knob Assembly
12	PC406-18	Air Stem Bushing
13	PC406-21	Shut Off Bushing
14	PC406-22	Trigger Holder
15	PC406-23	Gun Trigger
16	PC406-24	Retaining Ring (2)
17	PC406-25	Trigger Pin
18	PC406-27	Large O-Ring**
19	PC406-28	Shut Off Valve
20	PC560	Hopper Clamp
21	PC410	Ezy Deck Hopper Only
22	PC559W	ProForm® Hopper Only
23	PC555	Quick Coupler
-	PC406-19	Air Stem O-Ring (2) (Not shown) 9.25x1.78**
-	PC406-13	Gun Needle O-Ring (2) (Not shown) 10.82x1.78**
-	PC406-20	Shut Off Bushing O-Ring (Not shown) 11.5x1.5

KRAFT TOOL CO.®

8325 Hedge Lane Terrace
Shawnee, Kansas 66227 USA

800-422-2448

FAX 800-985-7238

www.krafttool.com

It is not necessary to completely disassemble the gun after each spray operation. It is advisable to remove the gun from the hopper so that the bowl in the gun can be easily flushed with water.

After cleaning the gun, place a few drops of oil around the air stem bushing (PC406-18) by turning the gun upside down and pulling back the trigger. Also, lubricate the Gun Needle (PC406-10) behind the trigger with a few drops of oil. (See Figure #6)

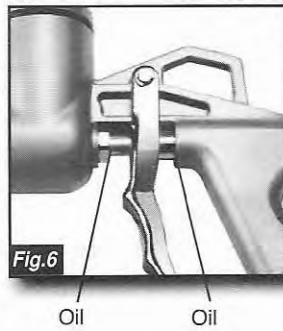

CAUTION:

When an extension cord is necessary, use at least 12 gauge cord, no longer than 100 ft. Extensions in excess of 100 ft may cause voltage drops resulting in damage to the electric motor.

The electric motor on your compressor unit is covered by a one year warranty by the original manufacturer. If motor problems develop contact the nearest authorized service center. If the situation is not handled to your satisfaction, please let us know.

Please follow these instructions before operating compressor:

(1) At the top of the compressor you will find the glass oiler assembly. Oil flows from this assembly into the compressor through a wick type feed. Only a small amount of oil is necessary to provide sufficient lubrication. (See Figure # 7)



(2) To fill with oil, remove top portion of assembly by unscrewing hex nut. When filling with oil keep downward pressure on the glass to prevent leakage. Use only 20 or 30 wt. Detergent oil. It is only necessary to fill with 1/2" to 1" of oil.

Caution: Overfilling will cause excessive lubrication and may result in malfunction.

(3) On each side of the compressor you will find oiler stems with silver caps. These carry oil to the shaft bearings. A few drops in each stem every 8 to 10 hours of operation will provide sufficient lubrication. (See Figure #8)

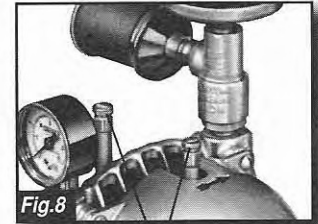

Caution: Do not fill stems with oil. Over oiling may result in malfunction.

Oiler Stems

PARTS LIST

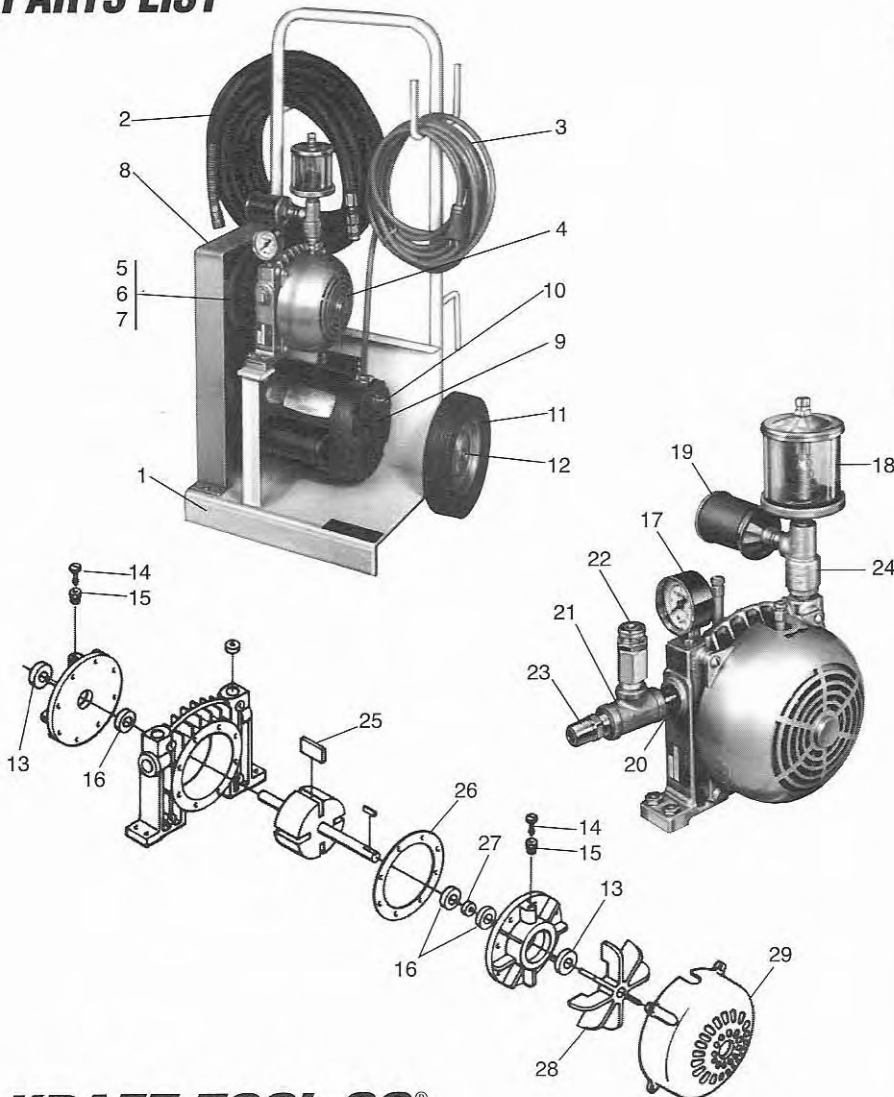

Compressor, Motor & Cart

Item	Part No.	Qty	Description
1	PC515	1	Frame
2	PC504	1	Air Hose Assembly
-	PC519	1	Quick Coupler Fitting
3	PC514	1	Power Cord
4	PC505	1	Compressor Assembly
5	PC521	1	Compressor Pulley
6	PC510	1	"V" Belt
7	PC520	1	Motor Pulley
8	PC512	1	Belt Guard
9	PC513	1	Motor Assembly with Switch
-	PC576	1	Motor with Power Cord
10	PC551	1	Motor Switch (Only)
11	PC522	2	Wheel
12	PC511	2	"C" Ring

Compressor Assembly PC505

Item	Part No.	Qty	Description
13	PC572	2	• Shaft Seal
14	PC528	2	Oiler Cap
15	PC571	2	Oiler Tube
16	PC573	3	• Shaft Bearing
17	PC526	1	Gauge, Pressure
18	PC523	1	Oiler Assembly
-	PC575	1	• Feed Wick
-	PC566	1	Oiler Gasket
-	PC567	1	Oiler Glass
19	PC524	1	Filter Assembly
-	PC565	1	End Cap, Filter
-	PC525	1	• Filter element
20	PC517	1	1/2" Close Nipple
21	PC516	1	1/2"x1/2"x3/8" Pipe Tee
22	PC530	1	Relief Valve
23	PC518	1	Brass Adaptor
24	PC527	1	Pressure Lubricator
-	PC570	1	Lubricator Coupler
25	PC531	4	• Vanes (Set of 4)
26	PC568	1	• Body Spacer
27	PC574	1	• Bearing Spacer
28	PC529A	1	Fan Blade
29	PC529	1	Fan Cover

• Denotes parts in Compressor Repair Kit #PC532

KRAFT TOOL CO.®

8325 Hedge Lane Terrace, Shawnee, Kansas 66227 USA